

WS Series Electric Pallet Truck With Lithium Battery Specification

		HANGCHA GROUP CO.,LTD.						
		Model	CBD18-WS-SE	CBD18-WS-SEQ	CBD15-WS	CBD18-WS		
Characteristics	1.1	Capacity	kg	1800	1800	1500	1800	
	1.2	Load center	mm	600	600	600	600	
	1.3	Standard overall fork width	mm	550/685	550/685	550/685	550/685	
	1.4	Fork length	mm	1150/1220	1150/1220	1150/1220	1150/1220	
	1.5	Overall length	mm	1552/1622	1552/1622	1552/1622	1552/1622	
	1.6	Overall height (with tiller)	mm	1300	1300	1300	1300	
	1.7	Rear body width	mm	550/685	550/685	550/685	550/685	
	1.8	Minimum turning radius	mm	1353/1426	1353/1426	1353/1426	1353/1426	
Performance	2.1	Max.Traveling speed	laden	km/h	3.5	3.5	4	4
			unladen	km/h	5	5	5	5
	2.2	Gradeability	laden	%	5	5	6	6
			unladen	%	20	20	20	20
	2.3	Traveling	kw	DC 0.75 Brushless	DC 0.75 Brushless	DC 0.75 Brushless	DC 1.0 Brushless	
2.4	Lifting	kw	Hydraulic	QUICK LIFT	DC 0.5	DC 0.5		
Battery	4.1	Voltage	v	48	48	48	48	
	4.2	Capacity/type	Ah	10 Ah Lithium	10 Ah Lithium	10 Ah Lithium	10 Ah Lithium	
Brake Type	5.1	Travel brake		Regenerate	Regenerate	Regenerate	Regenerate	
	5.2	Brake		Electromagnetic	Electromagnetic	Electromagnetic	Electromagnetic	
Controller	6.1	Controller		STAXB1501	STAXB1501	STAXB1501	STAXB1501	

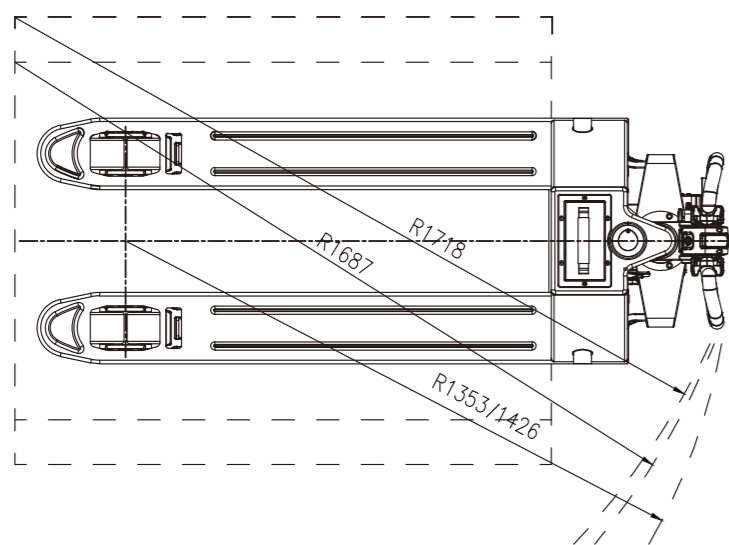
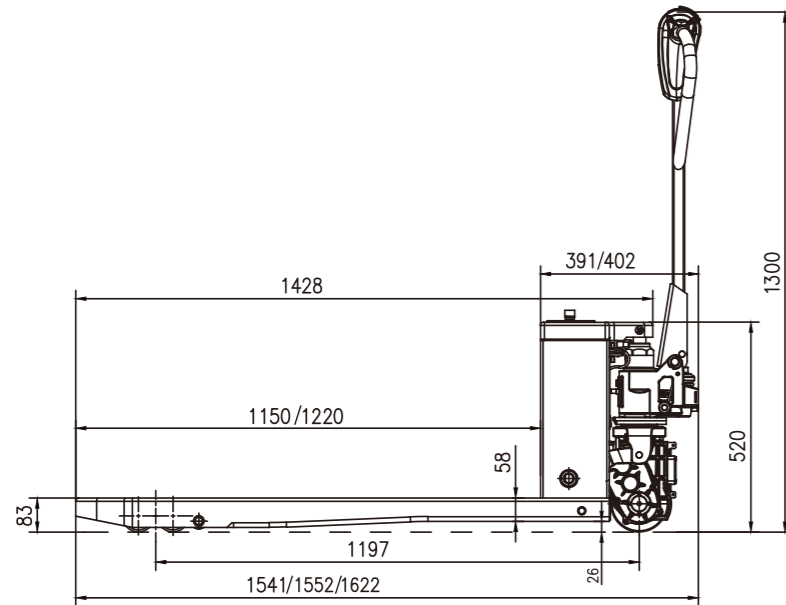

ZHEJIANG HANGCHA IMP. & EXP. CO., LTD.

Factory site: 666 Xiangfu Road,
Hangzhou, Zhejiang, China (311305)

Tel: +86-571-88926735 88926755
Fax: +86-571-88926789 88132890

sales@hcforklift.com
www.hcforklift.com



Follow us on Facebook



Follow us on YouTube



Follow us on WeChat



Download "Hangcha Forklift" App



ISO14001:2015



ISO9001:2015



HANGCHA trucks conform to the European Safety Requirements.

HANGCHA GROUP CO., LTD. reserves the right to make any changes without notice concerning colors, equipment, or specifications detailed in this brochure, or to discontinue individual models. The colors of trucks, delivered may differ slightly from those in brochures.

2020 VERSION 3/COPYRIGHT 2020/05



WS Series Electric Pallet Truck With Lithium Battery

with capacities of 1,500/1,800kg

The World of Hangcha
SINCE 1956



PERFORMANCE

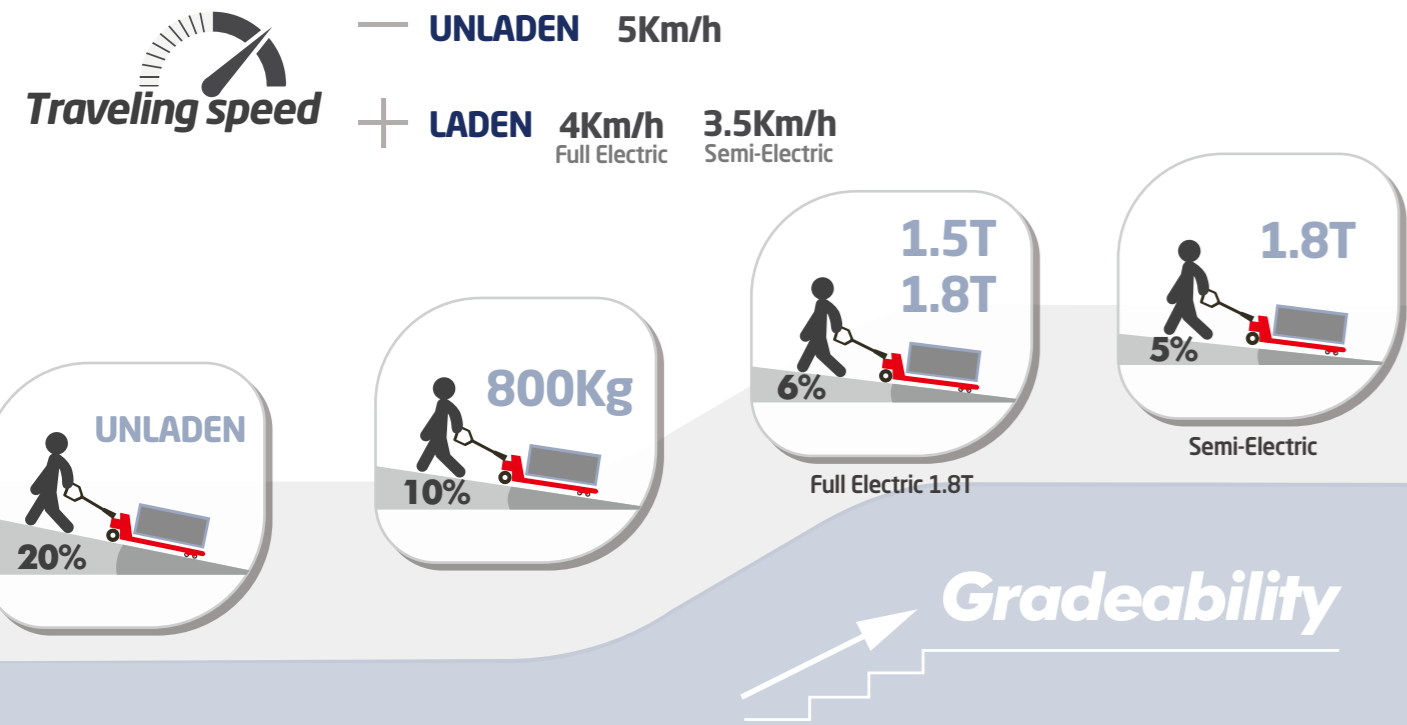

SMART FUNCTION

SMART FUNCTION 01

Turtle Speed
Horn Remains Pressed & Forward 2 times

SMART FUNCTION 02

Up-Right Drive
Reverse Button & Forward Throttle Remain Pressed, Power On

SMART FUNCTION 03

Engineering Mode (Brake Release)
Horn Remains Pressed, Power On

⚠ In up-right drive mode, vehicle will move when handle is operated at any position. Please avoid misoperation.

⚠ Brake release mode is only for emergencies, not allowed for vehicle with normal conditions.

CHARACTERISTICS

- Horn
- Emergency reverse button
- Forward/reverse butterfly switch
- Lifting / Lowering
- LCD Screen
 - Battery indicator with hour meter
 - Error code display
 - Recharge Alert

Multi-function Handle (Full Electric)

Multi-function Ergonomic Handle (Semi-electric)

OPTIONS



BUILT TO WORK 24 HOURS

SMART SIZE ALMOST SAME

LIGHT WEIGHT
ELECTRIC PALLET TRUCK ONLY 125kgs vs HAND PALLET TRUCK 80 kgs

EFFICIENCY
3 Times Higher Than Manual Pallet Truck

EASY MAINTENANCE

LIFETIME
3 Times Longer Than Manual Pallet Truck

1 PCS VS 3 PCS

PAY A LITTLE MORE SAVE MUCH MORE

MAINTENANCE SO EASY

- 5 YEAR WARRANTY CHASSIS**
- Brushless drive motor, maintenance free**
- Lithium-ion Lithium battery maintenance free**
- Recharge Alert**
- Error code display**
- 6s Replace Battery**
- 60s Replace Drive Wheel**

Integral Forks: Ideal design for closed pallet(single load wheel)

Manual: Lifting/Lowering

Electric Lifting/Lowering

Lithium battery pack